

► **Code Number**

3452674

► **Description**

Exposed, Sensor Activated Royal® Model Urinal Flushometer, for ¾" top spud urinals.

► **Flush Cycle**

0.5 gpf/1.9 Lpf

► **Specifications**

Quiet, Exposed, Dual Filtered Diaphragm Assembly, Chrome Plated Urinal Flushometer with the following features:

- Sweat Solder Adapter w/Cover Tube and Cast Wall Flange w/Set Screw
- OPTIMA® EL-1500 Self-Adaptive Infrared Sensor with Indicator Light
- Non-Hold-Open Integral Solenoid Operator, Fixed Metering Bypass and No External Volume Adjustment to Ensure Water Conservation
- High Back Pressure Vacuum Breaker Flush Connection with One-Piece Bottom Hex Coupling Nut, Spud Coupling and Flange for ¾" Top Spud
- Stop Seat and Vacuum Breaker molded from PERMEX® Rubber Compound for Chloramine Resistance
- Flush accuracy controlled by CID® technology
- ¾" I.P.S. Screwdriver Bak-Chek® Angle Stop with Vandal Resistant Stop Cap
- Infrared Sensor with Multiple-focused, Lobular Sensing Fields for high and low target detection

Valve Body, Cover, Tailpiece and Control Stop shall be in conformance with ASTM Alloy Classification for Semi-Red Brass. Valve shall be in compliance with the applicable sections of ASSE 1037 and ANSI/ASME 112.19.2.

► **Accessories (Sold Separately)**

See Accessories Section and OPTIMA® Accessories Section of the Sloan catalog for details on these and other OPTIMA® Flushometer variations.

► **Fixtures**

Consult factory for matching Sloan brand fixture options.

► **Control Circuit**

Solid State

8 Second Arming Delay

24 VAC Input

24 VAC Output

► **Solenoid Operator**

24 VAC, 50/60 Hz

► **Sensor Range**

Nominal 15"-30" (381 mm-762 mm), adjustable ± 8" (203 mm)

► **OPERATION**



► **Automatic Operation**

Sloan OPTIMA® equipped Flushometers provide the ultimate in sanitary protection and automatic operation. There are no handles to trip or buttons to push. The Flushometer operates by means of an infrared sensor that adapts to its surrounding. Once the user enters the sensor's effective range and then steps away, the Flushometer Solenoid initiates the flushing cycle to flush the fixture.

► **Economical**

Automatic operation provides water usage savings over other flushing devices. Reduces maintenance and operation costs.

► **Practical**

Solid state electronic circuitry assures years of dependable, troublefree operation. The operational components of the Flushometer are identical to a handle activated Royal® Flushometer, proven by over 100 years of experience.

► **Compliance & Certifications**



This space for Architect/Engineer Approval

1. A continuous, invisible light beam is emitted from the OPTIMA® Sensor.

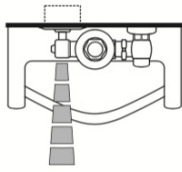

2. As the user enters the beam's effective range (15" to 30") the beam is reflected into the OPTIMA® Scanner Window and transformed into a low voltage electrical circuit. Once activated, the Output Circuit continues in a "hold" mode for as long as the user remains within the effective range of the Sensor.

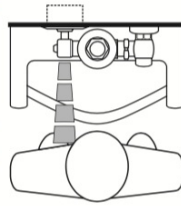

3. When the user steps away from the OPTIMA® Sensor, the circuit immediately initiates an electrical "one-time" signal that operates the Solenoid. This initiates the flushing cycle to flush the fixture. The Circuit then automatically resets and is ready for the next user.

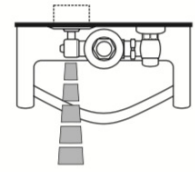

► WIRING DIAGRAM

One Transformer serves up to ten (10) OPTIMA Closet/ Urinal Flushometers. Specify number of transformers required accordingly.

► ELECTRICAL BOX INSTALLATION

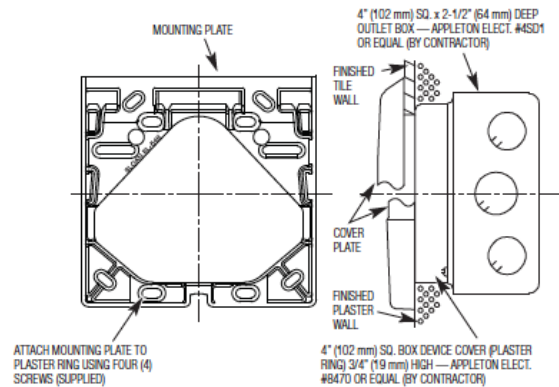

Failure to properly position the electrical boxes to the plumbing rough-in will result in improper installation and impair product performance. All tradesmen (plumbers, electricians, tile setters, etc.) involved with the installation of this product must coordinate their work to assure proper product installation. Installation Template furnished with Flushometer.

To ensure a perfect rough-in, Sloan recommends the use of the EL-485-A Flushometer Electrical Box Positioning and Support Kit. Specify and order the EL 485-A Kit separately. Consult factory for installation details.

► ROUGH-IN

